

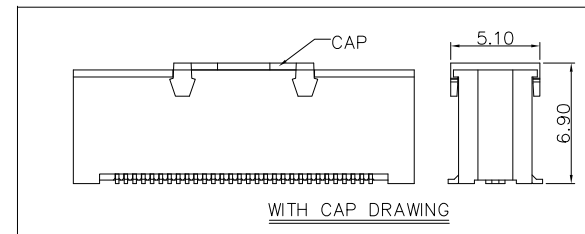

REV.	ECN. NO.	APPD.
A	ECN180117014	Darren Lei
B	ECN190701335	Mike Wu

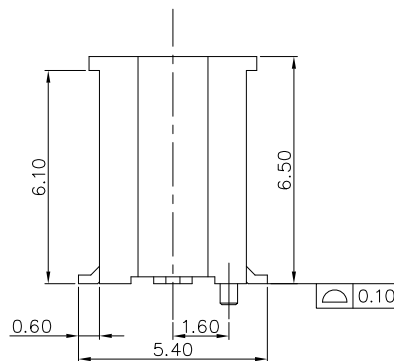
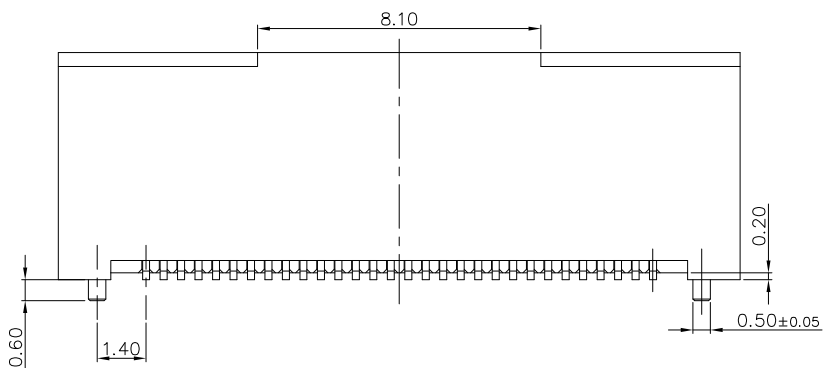
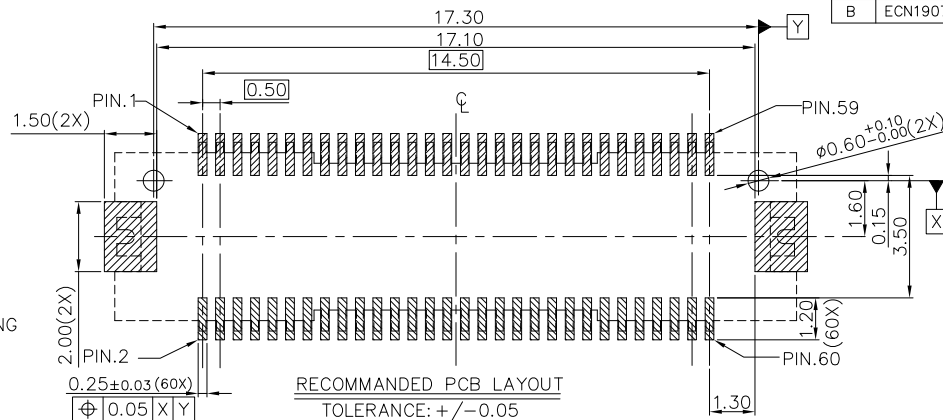
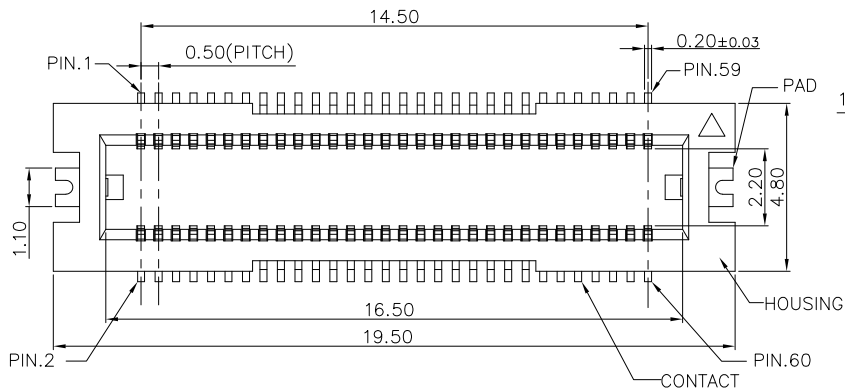

BT 5 P \*\* \*- 69 000-1 H HALOGEN FREE  
 5: 0.50PITCH  
 P: PLUG  
 POS NO:  
 60=60POS  
 PACKAGE CODE:  
 1: TAPE REEL  
 PROFILE HEIGHT  
 H=6.9mm

CONTACT AREA PLATING  
 1: 1u"MIN GOLD PLATING  
 4: 4u"MIN GOLD PLATING

NOTES:

- 1.DIMENSION SHALL BE INTERPRETED PER ASME Y14.5M-1994.
- 2.ELECTRICAL CHARACTERISTICS
  - 2.1 RATED CURRENT: 0.4A MAX.;
  - 2.2 CONTACT RESISTANCE: 75 mOHMS MAX.;
  - 2.3 INSULATION RESISTANCE: 1000 MOHMS MIN.;
  - 2.4 WITHSTANDING VOLTAGE: 500 VAC FOR 1 MINUTE MIN.;
- 3.MECHANICAL CHARACTERISTICS
  - 3.1 DURABILITY: 50 CYCLES
  - 3.2 VIBRATION: PASSED MIL-STD-202F,METHOD 201.
  - 3.3 SHOCK: PASSED MIL-STD-202F,METHOD 107D,CONDITION A.
- 4.ENVIRONMENT CHARACTERISTICS  
 OPERATION TEMPERATURE RANGE: -25°C TO +85°C .
- 5.PLEASE CONTACT DRAPHO SALES REPRESENTATIVE TO VERIFY PRODUCT DETAILS & AVAILABILITY.

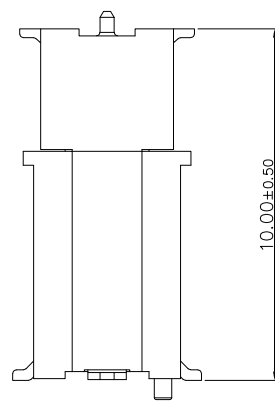

MATING VIEW

1	CAP	HIGHTEMP-PLASTIC	UL94V-0,BLACK
2	PAD	COPPER ALLOY	50u"MIN NICKEL UNDER PLATING. 100u"MIN MATTE TIN PLATING OVERALL.
60	CONTACT	PHOS-BRONZE	50u" MIN. NICKEL UNDER PLATING; 1u"MIN GOLD PLATING ON CONTACT AREA; 0.3u"MIN GOLD FLASH ON SOLDER AREA;
1	HOUSING	LCP	UL94V-0,BLACK
Q'TY	DESC.	MATERAIL	FINISH
UNITS: mm	GENERAL TOLERANCE		APPROVE: Mike Wu
DATE: 07/01'19	.X ±0.50 .X ±0.30 .XX ±0.20	X* ±2.00 .X* ±1.50 .XX* ±1.00	CHECKED: Mike Wu
SCALE: N/A			DRAW: Shan Chen
SHEET: 1/2	MATERIAL: N/A	Q'TY N/A	PART NO.(INTENDED USE) BT5P601-69000-1H
REV.: B	FINISH: SEE TABLE		TITLE: CUSTOMER DRAWING FOR 0.5P 60POS BTB REC.
			DRAWING NO.: 820-0000-0652
			Highstar Drapho ELECTRONICS TECHNOLOGY CO., LTD

AUTOCAD GENERATED DRAWING, DON'T CHANGE BY HAND.

RoHS

HF

REV.	ECN. NO.	APPD.
------	----------	-------

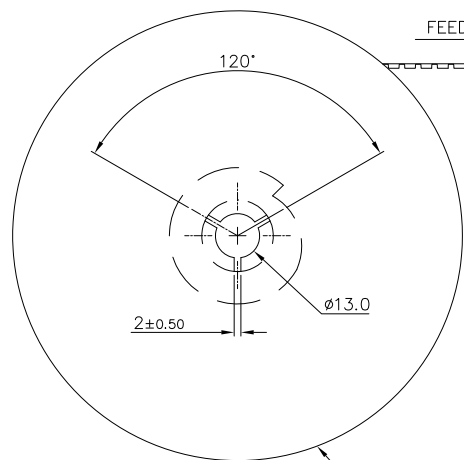
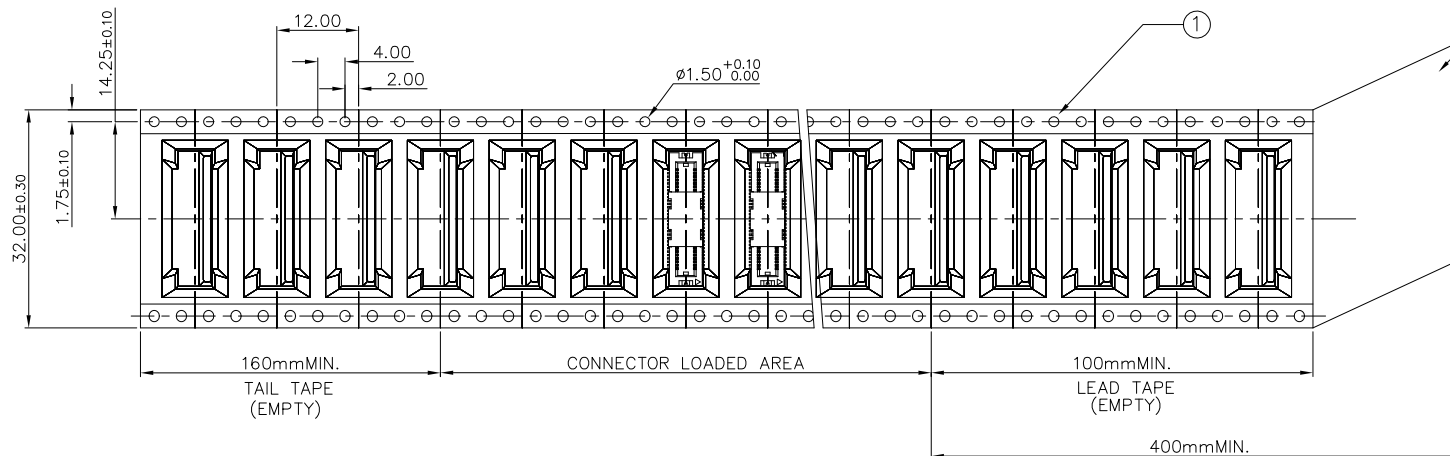

FEEDING DIRECTION

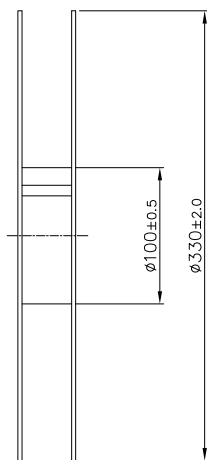

NOTES:

- 10 POCKETS HOLE PITCH CUMULATIVE TOLERANCE  $\pm 0.20\text{mm}$ .
- COVER TAPE PEELING STRENGTH : 0.01~0.13 Kgf AT 300mm/min.

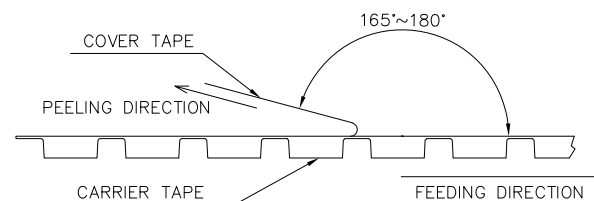

3. PACKAGING CAPACITY:

POS.NO.	PCS/REEL	REEL/BOX	PCS/BOX
60	600	5	3000

③	REEL	POLY STYRENE
②	COVER TAPE	PE
①	CARRIER TAPE	POLY STYRENE
ITEM	DESCRIPTION	MATERIAL

UNITS: mm	GENERAL TOLERANCE		APPROVED: Mike Wu	PART NO.(INTENDED USE) BT5P601-69000-1H
DATE: 07/01'19	X. : ±0.50 .X : ±0.30 .XX : ±0.20 .XXX	X.* : ±5* .X.* : ±2* .XX.* .XXX*	CHECKED: Mike Wu	TITLE: CUSTOMER DRAWING FOR 0.5P 60POS BTB REC.
SCALE: N/A	MATERIAL: SEE TABLE		DRAWING: Shan Chen	DRAWING NO.: 820-0000-0652
SHEET: 2/2	FINISH: N/A		Highstar Drapho ELECTRONICS TECHNOLOGY CO., LTD	
REV.: B				