

REV.	ECN. NO.	APPD.
A	ECN160411011	Fan Fang

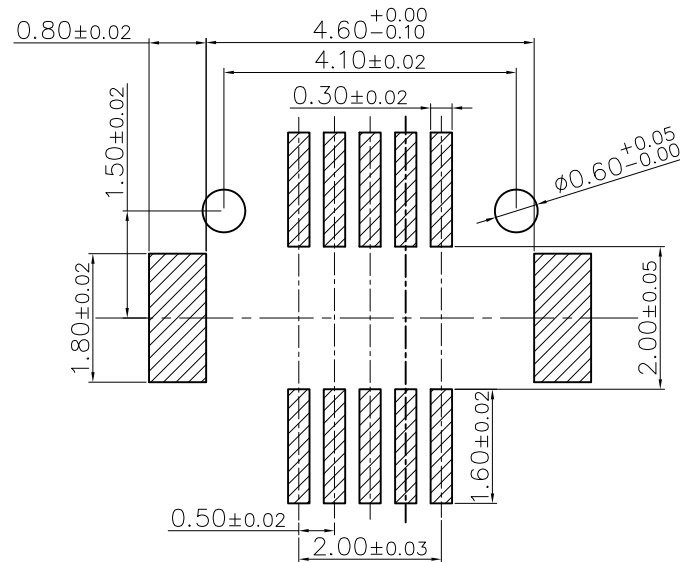

RECOMMENDED PCB LAYOUT

- NOTES:
- DIMENSION SHALL BE INTERPRETED PER ASME Y14.5M-1994.
  - MECHANICAL CHARACTERISTICS
    - MATING FORCE: AFTER DURABILITY: 19.8N MAX.
    - UNMATING FORCE: AFTER DURABILITY: 1.5N MIN.
    - DURABILITY: 50 CYCLES MIN.
    - CONTACT RETENTION FORCE: 0.98N MIN.
  - ELECTRICAL CHARACTERISTICS
    - RATED CURRENT: 0.5A MAX.;
    - RATED VOLTAGE: 30V MAX.;
    - WITHSTANDING VOLTAGE: 500 VAC FOR 1 MINUTE MIN.;
    - CONTACT RESISTANCE: 40 mOHMS MAX.;
    - INSULATION RESISTANCE: 500 MOHMS MIN.;
  - ENVIRONMENT CHARACTERISTICS
    - OPERATION TEMPERATURE RANGE: -40°C TO +85°C .
  - HARMFUL MATERIAL CONTROL MEET DSQC0042.

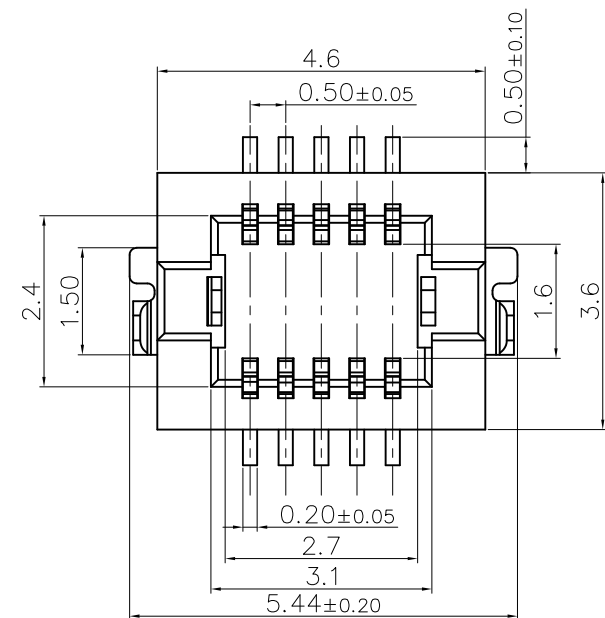
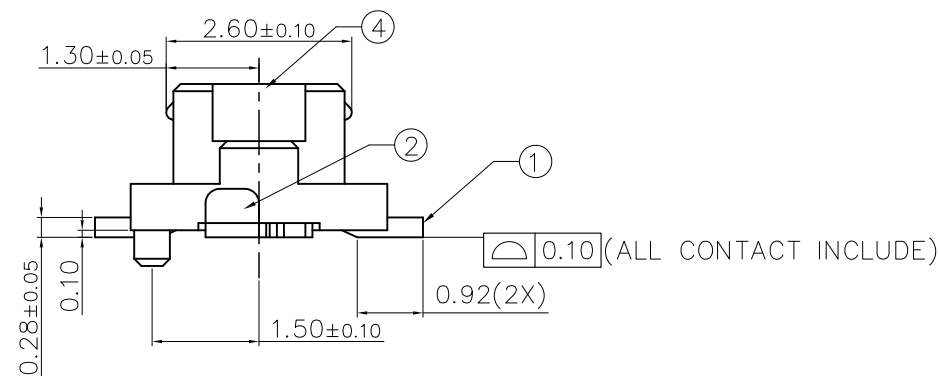
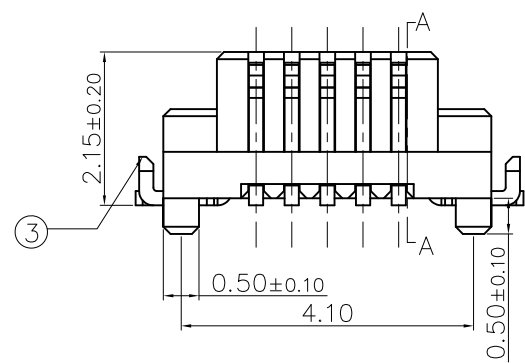

PART LIST

BT5 S 010 1-100 1 H  
 S : REC. LEAD FREE & HALOGEN FREE  
 Pos. No. PACKAGE TYPE  
 010:10 pos. 1: TAPE AND REEL  
 CONTACT AREA PLATING  
 1: 5 u" AU PLATING

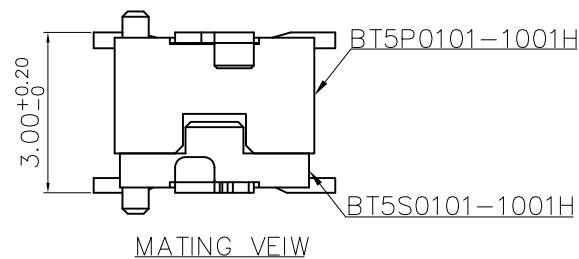
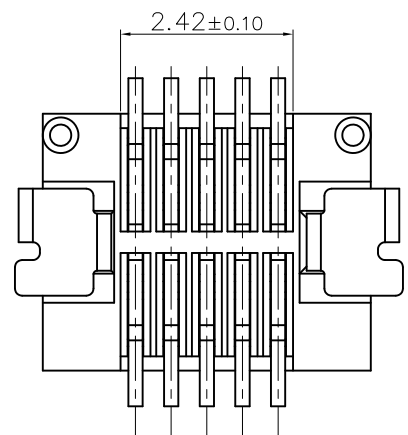

MATING VIEW

ITEM	DESCRIPTION	Q'TY	MATERIAL	FINISH	REMARK
④	HOUSING	1	THERMOPLASTIC	UL94V-BLACK	
③	PAD2	1	COPPER ALLOY	100u"MIN NICKEL UNDER PLATING; 100u"MIN MATTE TIN PLATING OVERALL.	
②	PAD1	1	COPPER ALLOY	100u"MIN NICKEL UNDER PLATING; 100u"MIN MATTE TIN PLATING OVERALL.	
①	CONTACT	1	COPPER ALLOY	100u" MIN NICKEL UNDER PLATING; 5u" MIN. GOLD FLASH ON CONTACT AREA ; 1u" MIN. GOLD PLATING ON SOLDER AREA .	
UNITS: mm		GENERAL TOLERANCE		APPROVE: Fan Fang	PART NO.: BT5S0101-1001H
DATE: 04/13'16	X. ±0.30	X.* ±5°		CHECKED: Daniel Yuan	TITLE: 0.5P PLUG BTB CUSTOMER DRAWING
SCALE: N/A	.X ±0.20	.X* ±3°		DRAW: Amanda Dai	DRAWING NO.: 820-0000-0377
SHEET: 1/2	MATERIAL: SEE TABLE	Q'TY: N/A		 Highstar Drapho ELECTRONICS TECHNOLOGY CO., LTD	
REV. A	FINISH: N/A				

NOTES:

- 10 PITCHES CUMULATIVE TOLERANCE ON TAPE  $\pm 0.20\text{mm}$ .
- COVER TAPE PEELING STRENGTH: 0.02~0.13kgf MAX AT 300mm/MINUTE.

3. PACKING CAPACITY:

P/N	PCS/REEL	REEL/BOX	PCS/BOX
BT5S0101-1001H	1500	10	15000

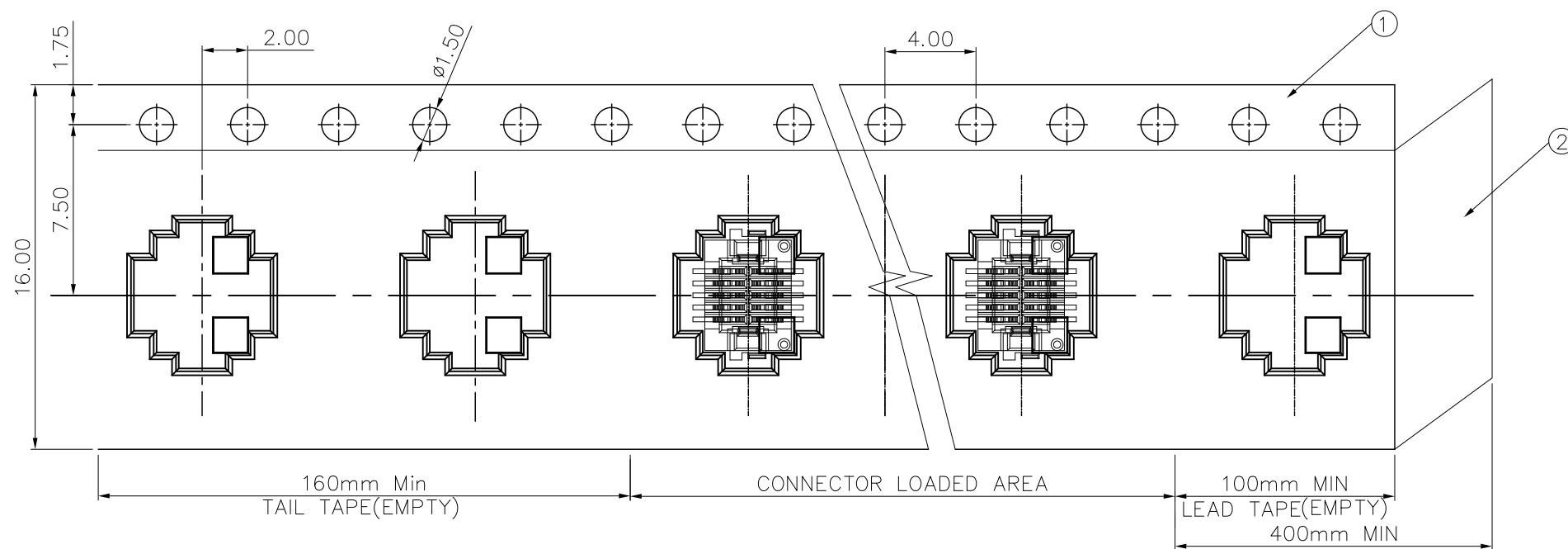
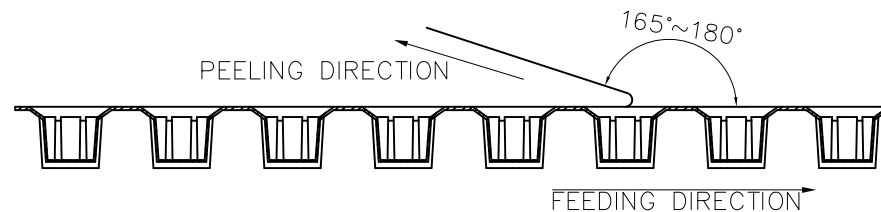
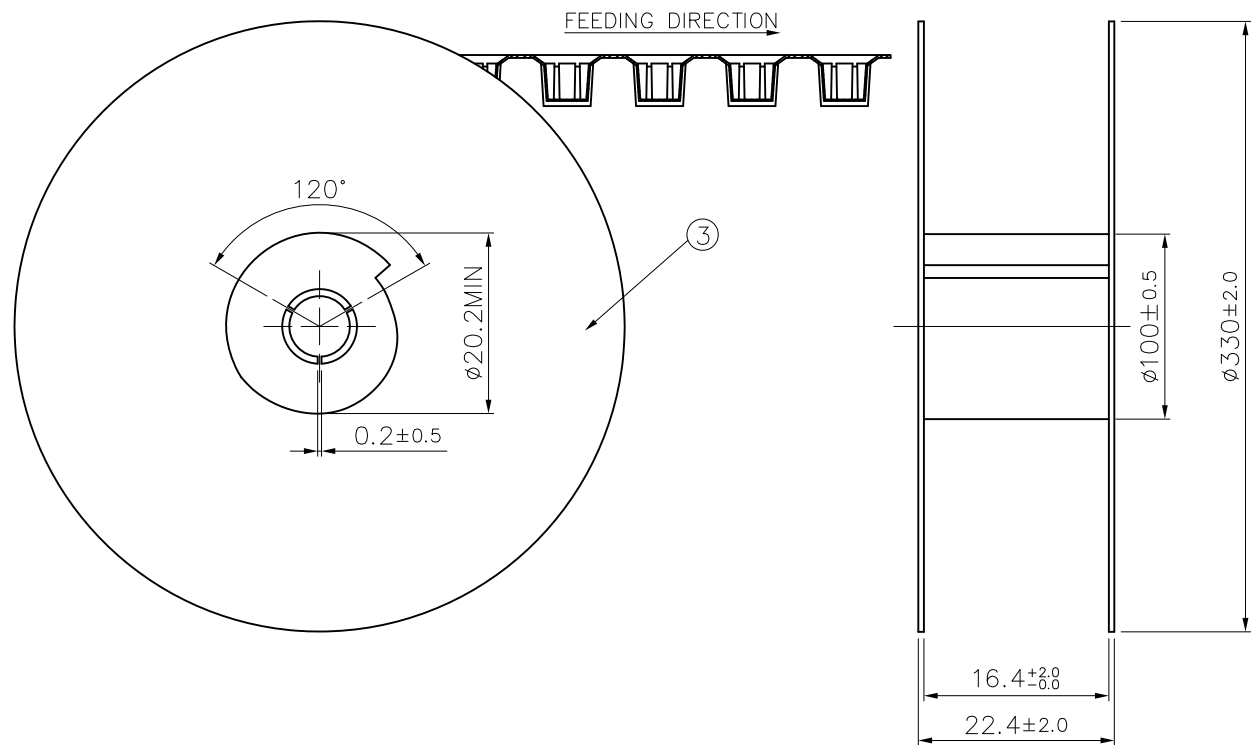

ITEM	DESCRIPTION	MATERIAL
③	REEL	POLYSTYPENE
②	COVER TAPE	POLYESTER
①	CARRIER TAPE	POLYSTYRENE

UNITS: mm	GENERAL TOLERANCE		APPROVE: Fan Fang	PART NO.(INTENDED USE) BT5S0101-1001H
DATE: 4/13'16	X. $\pm 0.30$	X.* $\pm 5.00^\circ$	CHECKED: Daniel Yuan	TITLE: BTB REC. CUSTOMER DRAWING
SCALE: N/A	.X $\pm 0.20$	.X* $\pm 3.00^\circ$	DRAW: Amanda Dai	DRAWING NO.: 820-0000-0377
SHEET: 2/2	MATERIAL: SEE TABLE	Q'TY N/A	 <b>Highstar</b> Drapho ELECTRONICS TECHNOLOGY CO., LTD	
REV.: A	FINISH: N/A	